

NARROW CORRUGATION (2.66" - 6.76 CM) SIX (6) FOOT DIA. HOPPER BOTTOM BIN ASSEMBLY AND INSTALLATION INSTRUCTIONS AND REPAIR PARTS LIST

MODEL NO.	DESCRIPTION	CAPACITY *
BB601	6 Ft. (1.83 Meters) Dia. / One 32"(81.3 cm) Ring	2.90 (2.6)
BB602	6 Ft. (1.83 Meters) Dia. / Two 32" (81.3 cm) Rings	4.40 (4.0)
BB603	6 Ft. (1.83 Meters) Dia. / Three 32" (81.3 cm) Rings	5.90 (5.40)

* Capacity is in 2000 pound tons & (metric tons). For additional specifications, see page 18 & 19.

WHEN ORDERING PARTS

- (1) Show MODEL NUMBER and NAME: Example - BB601 6 Ft. Dia. Hopper Bottom Bin.
 (2) Show PART NUMBER and FULL DESCRIPTION of part: Example - 907-0051 Caulking.

HOW TO ORDER PARTS

Repair parts may be ordered from your dealer.

TABLE OF CONTENTS

Table of Contents.....	1
Introduction and Safety.....	2, 3
Foundations.....	4
Anchoring.....	4
General Information.....	5
Hardware and Brace Descriptions & Bolt Head Placement.....	5-7
6' dia. Assembly Instructions.....	8-18
Top Body Ring.....	8
Roof & Collar.....	9, 10
Lower Body Rings.....	11
Hopper & Collar.....	12-14
Legs.....	15
Bracing.....	15
Ladder Assembly.....	16
Setting Bin Upright.....	17
Securing the Bin to the Foundation.....	18
Bin Grounding.....	18
Chart of Capacities, Narrow.....	18
Height Specifications, Narrow.....	19
Bill of Materials/Repair Parts List, Narrow.....	20
 Wide Corrugation Assembly - Models 6015, 6025 and 6035.....	 21
Chart of Capacities, Wide.....	22
Height Specifications, Wide.....	22
Bill of Materials/Repair Parts List, Wide.....	23
Field Modification and Maintenance.....	24



PO BOX 2000 • HOUGHTON, IOWA 52631 USA
 PHONE 319-469-4141 FAX 319-469-4402
 www.hawkeyesteel.com E-mail: sales@hawkeyesteel.com

INTRODUCTION AND SAFETY

Thank you for purchasing your hopper bottom bin from Hawkeye Steel Products, Inc. (HSPI)

Check the materials received against the packing list to ensure all materials are present.

Read all safety information and instructions thoroughly **BEFORE** starting construction. **SEE SAFETY CONSIDERATIONS AND SEE BIN GROUNDING ON PAGE 18.**

Optional equipment contains necessary assembly and operation instructions.

Choose the site for your bin carefully. Leaving space for future expansion is a prime consideration. The soil of your bin site should have a uniform load bearing capacity of at least 3500 pounds-per-square-foot (about 17,100 kilograms per square meter) and have good drainage.



**Bin installations must meet all applicable local and national codes.
Check with the proper authorities before beginning installation.
Bin must be grounded. See page 25.**

READ ALL DIRECTIONS CAREFULLY BEFORE BEGINNING INSTALLATION



Read and follow all safety precautions for any power tools to be used during this installation! Failure to follow these safety precautions could result in electrical shock or serious injury causing disfigurement or death!

Safety is just as important as the productivity of your bin. This section serves as a guide to help and encourage a safe operation. However, it is your responsibility to evaluate each operation and to determine and implement the best method of protecting yourself as owner and/or operator. Establish and promote a program of safety that assures safe working practices.

CONSTRUCTION SAFETY

1. Low spots that could collect water should be eliminated so as not to come in contact with electric cords used in construction.
2. Ground all electrical equipment.
3. In planning the location, take into consideration any areas that could present an unsafe situation. Avoid power lines that could come in contact with bin.
4. Keep safety guards on equipment.
5. Wear eye protection when using drills or saws on equipment causing flying debris.
6. Wear hard hats during construction.
7. Plan a way to secure tools, parts, and equipment when working above others.
8. Take care not to lift items too heavy. Avoid back and muscle injury.

PRE-OPERATION SAFETY

1. Check electrical performance and lock outs on equipment.
2. Check again for unsafe areas and be sure all are identified with warning labels.

OPERATION SAFETY

1. Do not enter hopper bin during operation.
2. Never enter bin with bridged material
3. Read and re-read all warning labels.
4. Be absolutely sure electricity is locked out when working with or near moving parts.
5. Do not bypass electrical safety equipment. Make sure electrical equipment is properly installed and grounded by a qualified electrician.
6. Keep all extremities away from moving parts.
7. Be sure guards and safety devices are correctly installed and in proper position.
8. Call HSPI before making field modifications to make sure the changes do not alter strength and/or safety of the bin.
9. Know who or where to call for immediate help in the event of an emergency or injury.
10. Keep area around bin free of clutter and debris.

DANGER

! YOU CAN SUFFOCATE UNDER GRAIN IN THIS BIN !

DO NOT ENTER WHEN THIS BIN IS BEING LOADED OR UNLOADED.

— IF YOU MUST ENTER THE BIN —

1. SHUT OFF AND LOCK OUT ALL POWER.
2. USE A SAFETY HARNESS AND SAFETY LINE.
3. WEAR A DUST RESPIRATOR.
4. AVOID THE CENTER OF THE BIN.
5. STATION A PERSON TO HELP FROM OUTSIDE THE BIN.

— FLOWING GRAIN —



FLOWING GRAIN TRAPS AND SUFFOCATES

AND

— CRUSTED GRAIN —



CRUSTED GRAIN COLLAPSES AND SUFFOCATES

FOUNDATIONS

Foundations— must be placed on soil with a uniform load bearing capacity of 3500 pounds-per-square-foot (about 17,100 kilograms per square meter), or special foundations must be considered. Contact a qualified soil engineer to answer any questions you may have.

- Foundations must be designed per local soil and frost depth conditions.
- Foundations must be smooth and level.

Concrete in footings must have a minimum compressive strength of 3000 pounds-per-square-inch (about 211 kilograms per square centimeter).

Concrete reinforcing shall have a minimum yield strength of 33,000 pounds-per-square-inch (about 2320 kilograms per square centimeter).

Anchor bolt dimensions are the same for square or round foundations. Dimensions are in inches (centimeters).

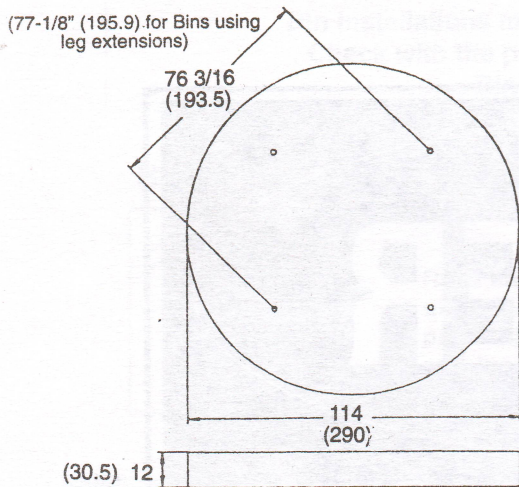

2.60 cu. yds.
(1.99 cu. meters)

(add 25% for waste)

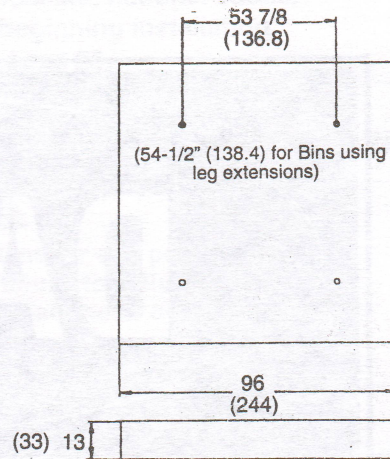

2.60 cu. yds.
(1.99 cu. meters)

ANCHORING

Use a 5/8" dia. (1.6 cm) x 8" (20.3 cm) x 2" (5.1 cm) 'L'-Bolt with a required embedded depth of 6-1/2" (16.5 cm).

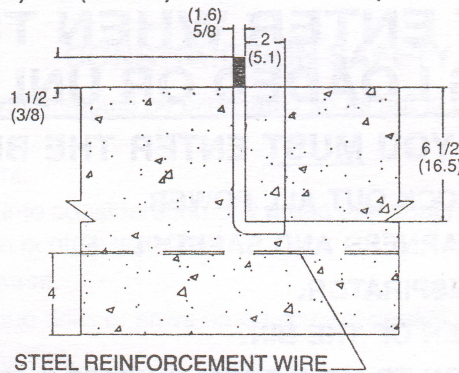

ALTERNATIVE ANCHORING

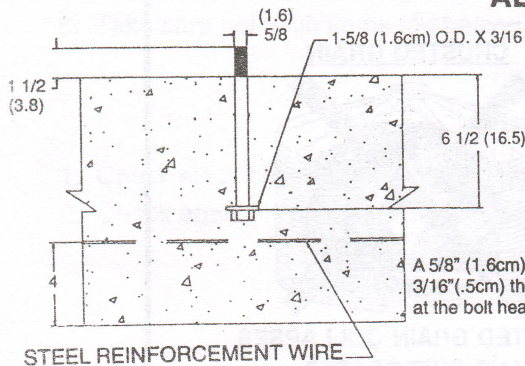

When using drill-in type anchor bolts, each bolt must be 5/8" dia. (1.6cm) and have a minimum embedment of 7" (17.8cm).

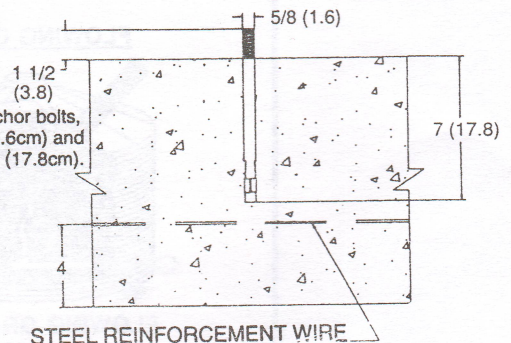

A 5/8" (1.6cm) x 8" (20.3cm) hex head bolt with 3/16" (.5cm) thick x 1-5/8" (4.1cm) O.D. washer at the bolt head with a 6-1/2" (16.5cm) embedment.

GENERAL INFORMATION & HARDWARE USAGE

1. Bolt hole spacing at the top and bottom of the bottom body ring, and at the top of any additional rings, is 2-11/32" (5.95cm). Bolt hole spacing at the bottom of upper body rings is 9-3/8" (23.8cm).
2. Overlap vertical body ring seams in the same direction. (See EXHIBIT C, page 8). Install each consecutive upper body ring to the inside of the ring above it, and stagger overlapping vertical body seams (See EXHIBIT-H, page 11).
3. **NOTE FASTENER USAGE BELOW AND ALSO SEE EXHIBIT A.**

Location	Type of Fastener	Bolt Head on the
Roof to Collar	5/16" x 3/4" (.8 cm x 1.9cm) truss head/hex flange nut	outside
Vertical Roof Seams	5/16" x 3/4" (.8 cm x 1.9cm) hex head/hex nut	outside
Roof to Body	5/16" x 1 1/4" (.8 cm x 3.2cm) hex head/hex nut	outside
Vertical Body Seams	5/16" x 1 1/4" (.8 cm x 3.2cm) hex head/hex nut	outside
Horizontal Body Seams	5/16" x 1 1/4" (.8 cm x 3.2cm) hex head/hex nut	outside
Hopper to Body	5/16" x 1 1/4" (.8 cm x 3.2cm) hex head/hex flange nut	outside
Vertical Hopper Seams	5/16" x 3/4" (.8 cm x 1.9cm) truss head/hex flange nut	inside
Hopper to Collar	5/16" x 3/4" (.8 cm x 1.9cm) truss head/hex flange nut	inside
Collar to Plastic Transition	5/16" x 3/4" (.8 cm x 1.9cm) truss head/nylon nut	inside
Hopper Brace to Collar	5/16" x 3/4" (.8 cm x 1.9cm) truss head/hex flange nut	inside
Hopper Brace to Leg	5/16" x 3/4" (.8 cm x 1.9cm) hex head/hex nut	outside
Leg to Body	5/16" x 1 1/4" (.8 cm x 3.2cm) hex head/hex nut	inside

4. **IMPORTANT- DO NOT TIGHTEN ANY BOLTS MORE THAN FINGER TIGHT UNTIL SPECIFIED!! BOLTS ARE ALWAYS TIGHTENED FROM THE NUT SIDE ONLY (except where noted) TO PREVENT DAMAGE TO THE RUBBER SEALS.**

NOTICE		
Bin bolts must be <u>tight</u> . The following table contains recommended minimum and maximum torque values:		
Bolt Diameter	Torque (Ft. - Lbs.)	
5/16" (.8 cm)	Minimum	Maximum
	14	18
Tighten bin bolts from the nut end of bolt to eliminate "spin-off" of sealing washer.		
<u>Use only those bolts supplied by the bin manufacturer. The substitution of bolts from other sources is not permitted.</u>		

5. Please refer to the diagrams on page 7 for hardware descriptions and bolt head placement.
6. Roof & Hopper Sheet identification(6' Bin)

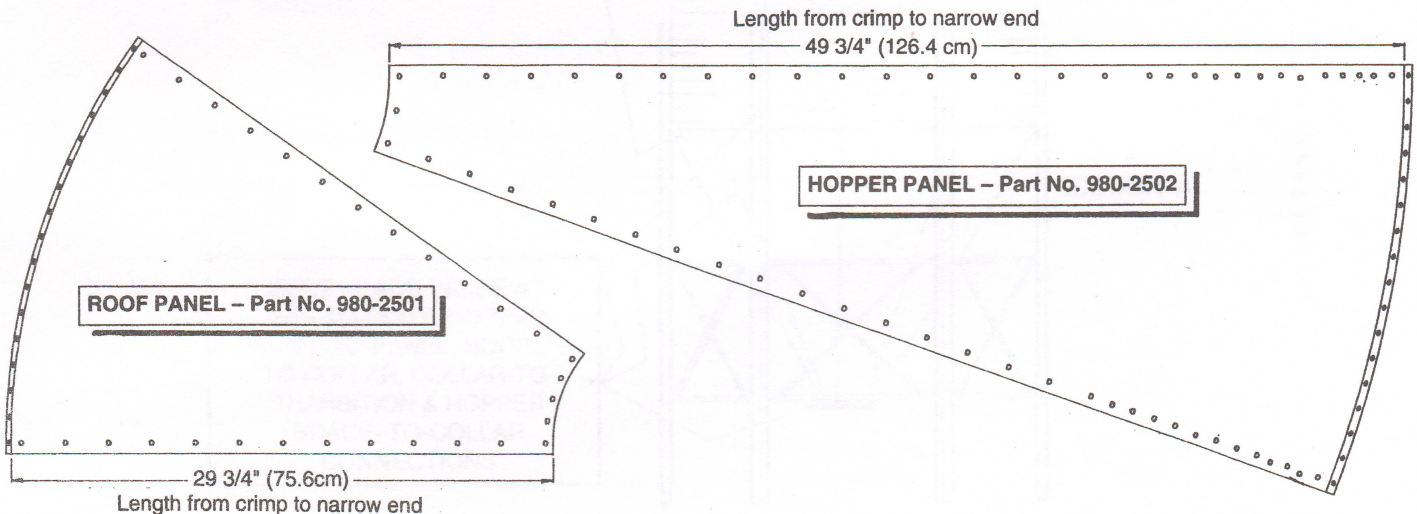

7. Angle Identification (6' Bin)

Part No.	Description	Length	Quantity
980-2504	Leg to Collar Brace	27 3/4" (70.5 cm)	4

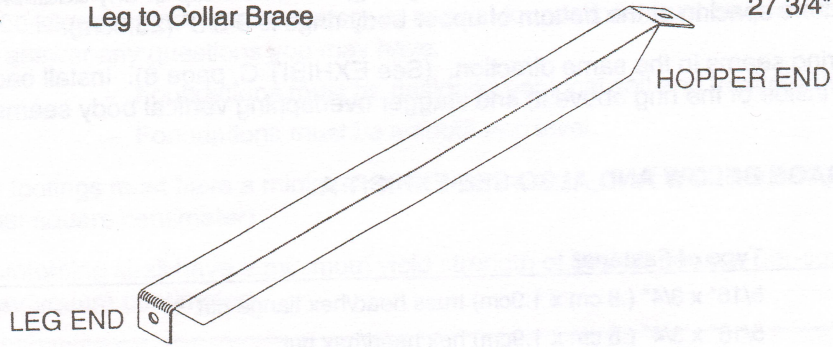

980-2506	Ladder Stand-Off angle	53" (134.6 cm)	1
----------	------------------------	----------------	---

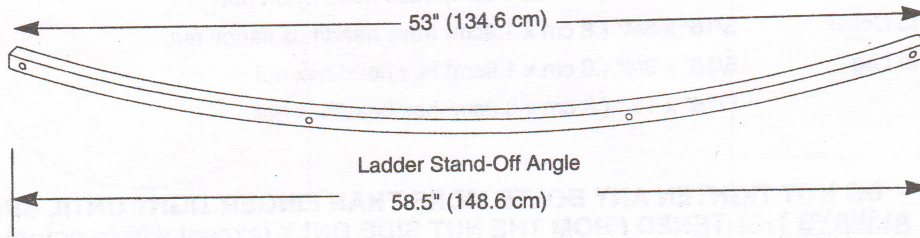

on the main page. The following table contains the part numbers and descriptions for the parts shown in the diagrams on page 6. The part numbers and descriptions are listed in the table below. The part numbers and descriptions are listed in the table below. The part numbers and descriptions are listed in the table below.

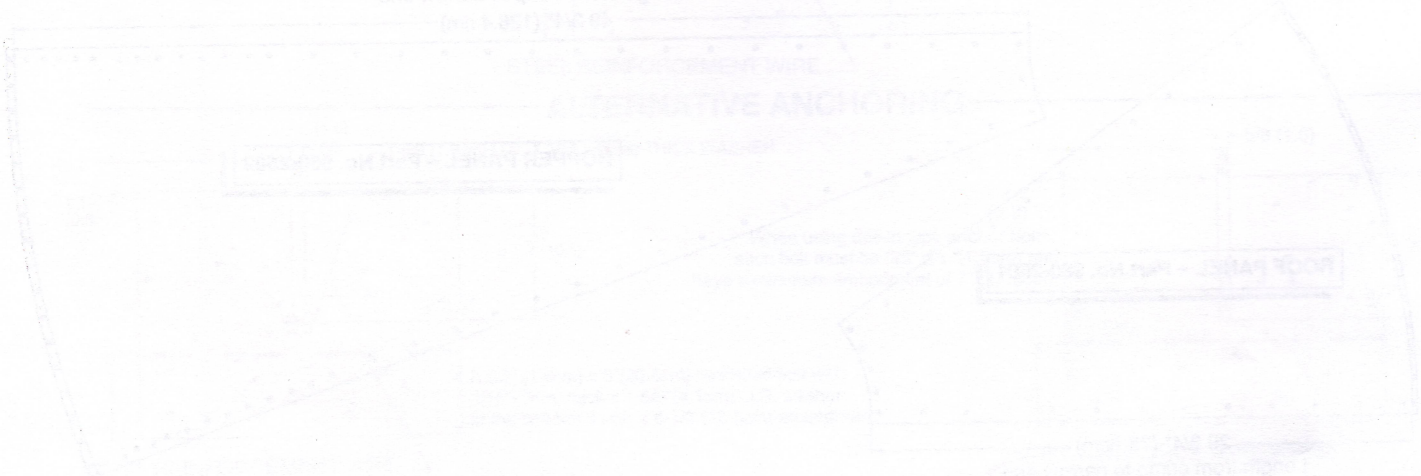

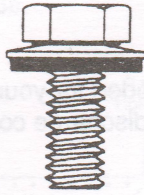
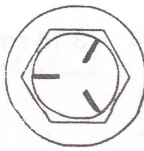

5/16-18 x 3/4 NC
(M8 x 1.25 x 20)
Hex Head Bolt
Grade-5 with
Rubber Backed Washer

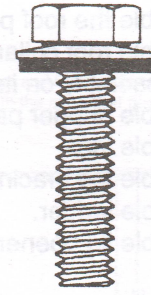
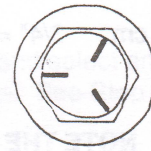

5/16-18 x 1-1/4 NC
(M8 x 1.25 x 30)
Hex Head Bolt
Grade-5 with
Rubber Backed Washer

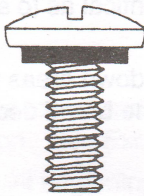
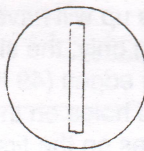

5/16-18 x 3/4 NC
(M8 x 1.25 x 20)
Slotted Truss Head
Machine Screw
Grade-8
with Neoprene-Seal



5/16-18 NC
(M8 x 1.25)
Hex Nut

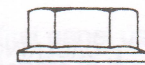
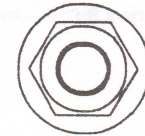

5/16-18 NC
(M8 x 1.25)
Hex Flange Nut

BOLT HEADS OUTSIDE AT ROOF-TO-COLLAR,
ROOF PANEL-TO-PANEL, ROOF-TO-BODY,
HOPPER-TO-BODY, & VERTICAL BODY SEAMS

BOLT HEADS INSIDE AT
LEG-TO-BODY, HOPPER
PANEL-TO-PANEL, HOPPER-
TO-COLLAR, COLLAR-TO-
TRANSITION & HOPPER
BRACE- TO-COLLAR
CONNECTIONS

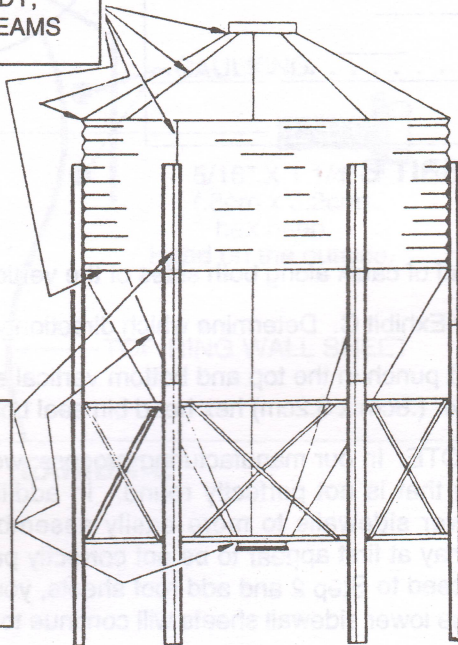

EXHIBIT A

5/16" = .8 cm 3/4" = 1.9 cm 1" = 2.54 cm 3/8" = .95 cm 1 1/4" = 3.18 cm 1 1/2" = 3.8 cm

ASSEMBLY

IMPORTANT! NOTE THE GENERAL ORDER OF ASSEMBLY

1. Assemble the top ring in an upright position.
2. Assemble the roof panels to top ring.
3. Assemble roof collar to roof panels.
4. Turn assembly on its side and continue to add sidewall sheets as needed for your size bin.
5. Assemble hopper panels to the lower sidewall sheets and assemble discharge collar to hopper panels.
6. Assemble legs.
7. Assemble leg bracing.
8. Assemble ladder.
9. Assemble lid opener.

STEP 1: TOP BODY RING – Begin assembly of your bin with the top sidewall sheets. In this step assemble the 2 top sidewall sheets **ONLY**.

If your bin has more than one ring, the top sidewall sheets will not have any vertical rows of holes for the legs. The edge up will have more horizontal holes than the edge down. If your bin has one ring only, the sidewall sheets will have an equal number of horizontal holes on both edges (49 holes). The edge that goes down (to mate with hopper sheets) has holes on the second row of corrugation. The edge that goes up has holes on the first (or outside) row of corrugation. All upper sidewall sheets (other than the lower ring) on 2 ring, 3 ring and 4 ring six foot diameter bins are identical as to size and hole placement. See Exhibit D.

Stand the two top sheets on edge and wipe down areas where caulking is to be applied. One of these sheets should carry the brand decal.

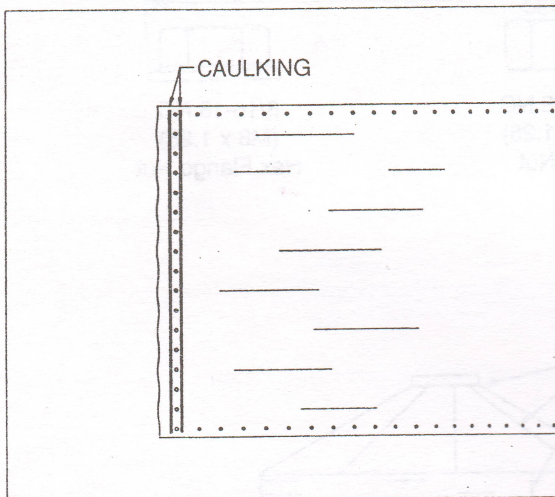
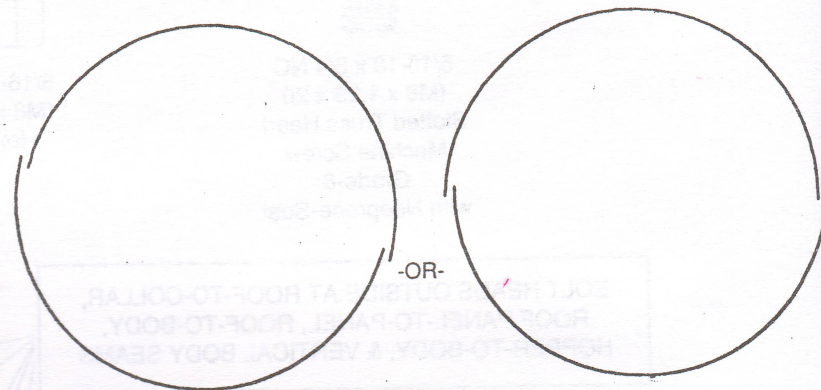

EXHIBIT B



MAINTAIN THE SAME OVERLAPPING PATTERN FOR ALL BODY RINGS

EXHIBIT C

Apply a bead of caulk along both sides of the vertical row of bolt holes. See Exhibit B.

Now review Exhibit C. Determine which direction you will be overlapping the body sheets.

Using a drift punch in the top and bottom vertical seam holes, bolt the vertical seams together, using 5/16" x 1 1/4" (.8cm x 3.2cm) hex head bin seal bolts with bolt heads on the outside.

PLEASE NOTE: In our manufacturing process, we may have side wall sheets that when assembled form a ring that is not perfectly round. In addition, our vertical holes are slightly tapered which permits lower sidewalls to more easily assemble to upper sidewalls. Thus, your top sidewall assembly may at first appear to be not correctly punched or to not have proper curvature. However, as you proceed to Step 2 and add roof sheets, your sidewalls will round out. Further, adding hopper panels to the lower sidewall sheets will continue to round out the sidewall assembly.

STEP 2: ROOF PANELS – Take the top body ring you have just assembled and select an upper sidewall sheet with no decal. Place sidewall sheet on edge. See Step 1 and Exhibit D for which edge goes up.

Take a marker and mark as shown in Exhibit D write the word "Leg", "Roof", "Ladder" or use your own code.

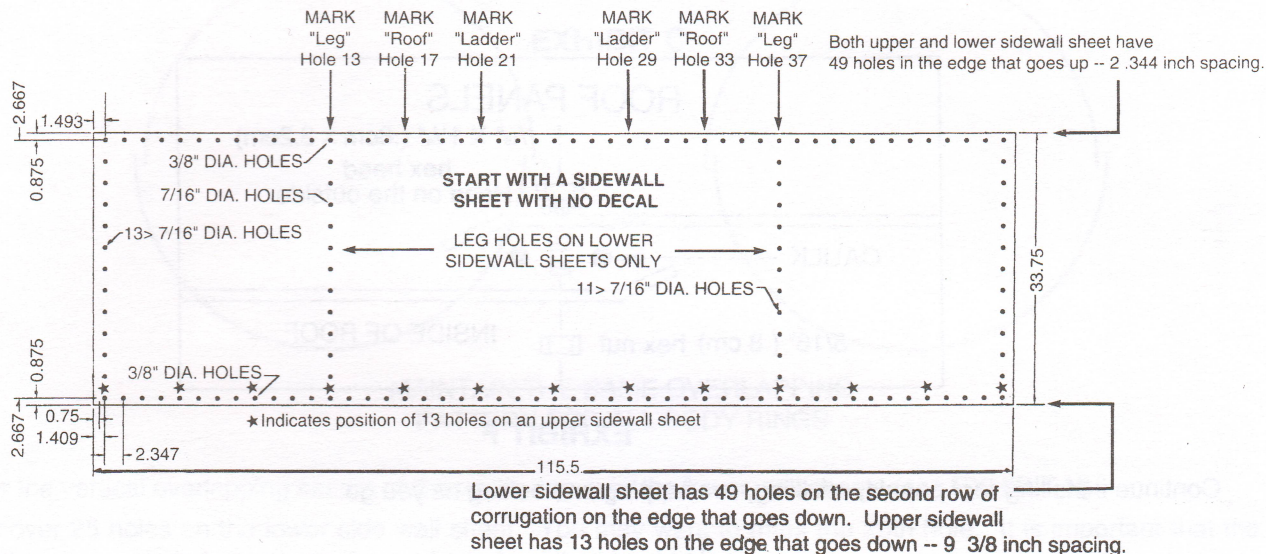

EXHIBIT D

Wipe the outside of the top of each ring, as well as all roof panel seams and caulk on both sides of each row of holes before installation. See Exhibit D.

Place the first roof panel beginning in hole 17 as indicated in Exhibit D. Install the first panel using 5/16" X 1 1/4" (.8 cm x 3.2 cm) hex head bin seal bolts with heads on the outside. Do not put fasteners in the 2 holes marked "LADDER" -- hole 21 and hole 29.

Do not tighten any roof or roof collar fasteners until instructed to do so in Step 3.

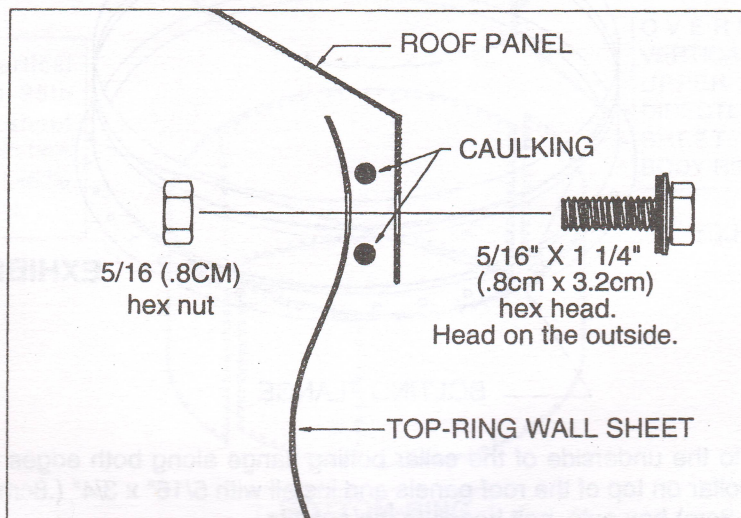

EXHIBIT E

After the first roof panel has been installed, begin installation of the second panel. Add 2 rows of caulk on the vertical roof panel holes. Use 5/16" x 3/4" (.8cm x 1.9cm) hex head bin seal bolts, heads on the outside.

NOTE: MAKE SURE THAT THE SECOND ROOF PANEL'S EDGE HAS A DOWNWARD BEND AND THE FIRST ROOF PANEL'S EDGE HAS AN UPWARD BEND. SEE EXHIBIT F.

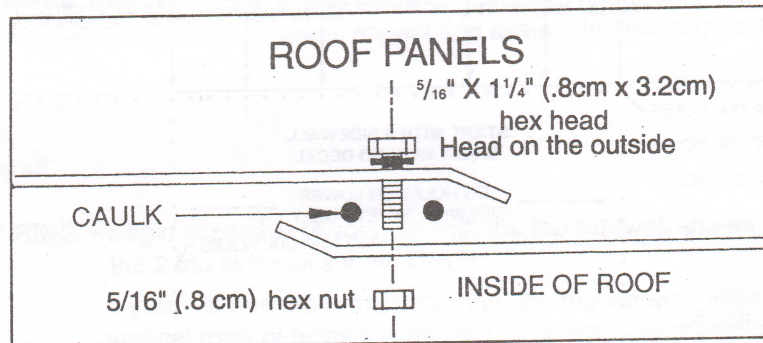
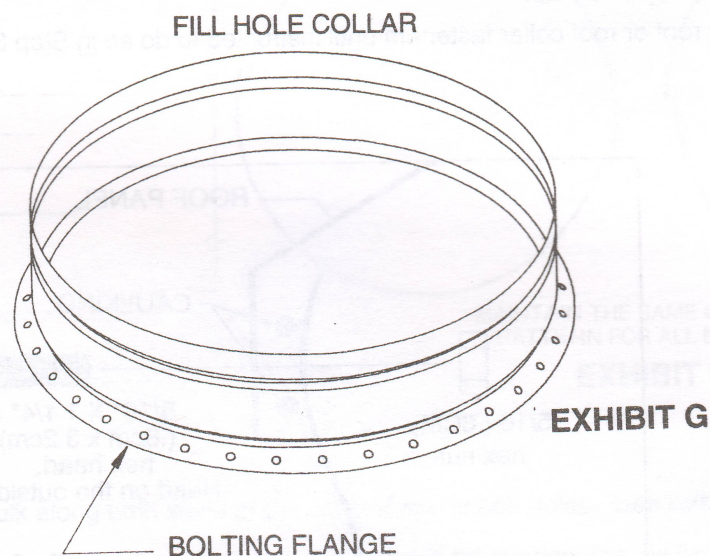

EXHIBIT F

Continue installing roof panels, caulking, overlapping and bolting as you go.

STEP 3: ROOF COLLAR – After all the roof panels are attached, locate the fill hole collar (24" dia. with 36 holes in it's bolting flange) in its separate carton. (see EXHIBIT G.)



Apply a bead of caulk to the underside of the collar bolting flange along both edges of the circle of bolt holes. Place the collar on top of the roof panels and install with 5/16" x 3/4" (.8cm x 1.9cm) truss head bolts and 5/16" (.8cm) hex nuts, bolt heads to the outside.

ROOF TIGHTENING SEQUENCE – Now you can begin tightening the bolts in the roof. First tighten all the bolts, FROM THE NUT SIDE ONLY, in the roof-to-body seam, including the body ladder overlapping connection. Next tighten the bottom four bolts, FROM THE NUT SIDE, in all roof panel overlapping seams. Then tighten the remaining bolts in the roof panel overlapping seams, FROM THE NUT SIDE, working from the bottom up. Tighten roof seams in consecutive clockwise or counter-clockwise order. Do not jump from one side of the bin to another.

STEP 4: SIDEWALL SHEETS – Turn the roof panel and upper sidewall assembly on its side. Continue to add sidewall sheets by following these directions. Determine which direction you will be overlapping the body sheets (see EXHIBIT C).

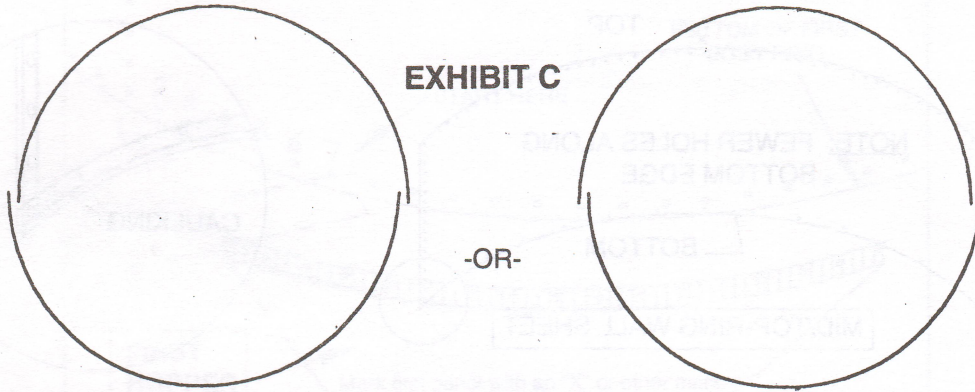

MAINTAIN THE SAME OVERLAPPING PATTERN FOR ALL BODY RINGS

Center the vertical overlapping seams of the upper ring over the lower wall sheets (see EXHIBIT H).
Count over 25 holes on the lower side wall sheet. You may want to mark the 25th hole. It is important that the vertical seam be placed exactly on the center hole of the sheet below.

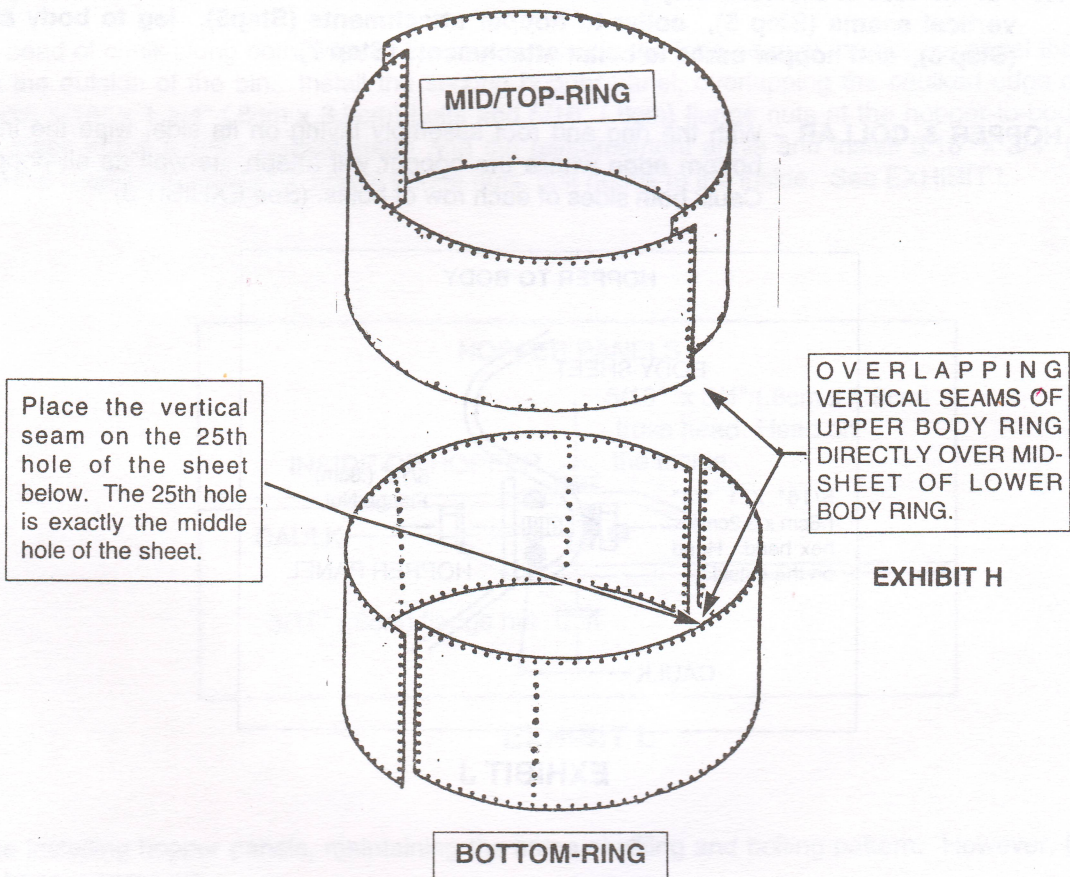

IMPORTANT! THE HORIZONTAL EDGE OF THE LOWER RING SHEETS GO UNDERNEATH THE HORIZONTAL EDGE OF THE UPPER RING SHEETS.

Wipe sidewall sheets along bolt holes.

Apply a bead of caulk along both edges of the line at bolt holes at the ends of the body sheets.

Also apply a bead of caulk along both edges of the vertical row of holes at each end of the second body-ring sheets. See EXHIBIT I

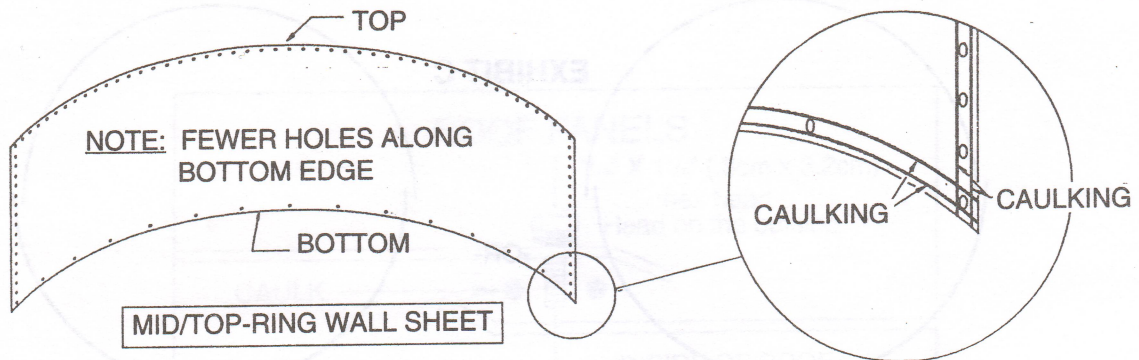

EXHIBIT I

Use an alignment punch to align holes. Horizontal body seams use 5/16" x 1 1/4" (.8cm x 3.2cm) hex head bin seal bolts. Vertical seams use 5/16" x 1 1/4" (.8cm x 3.2cm) hex head bin seal bolts. Bolt heads go on the outside of the bin. After all bolts are in place, tighten horizontal seams from the center of each body sheet out to the vertical seams.

IMPORTANT: For the rest of the assembly please note that bolt heads are inside of the bin at all hopper vertical seams (Step 5), collar to hopper attachments (Step 5), leg to body attachment (Step 6), and hopper brace to collar attachments (Step 7).

STEP 5: HOPPER & COLLAR – With the ring and roof assembly laying on its side, wipe the inside of the bottom edge where the hopper will attach, as well as all hopper seams. Caulk both sides of each row of holes. (See EXHIBIT J)

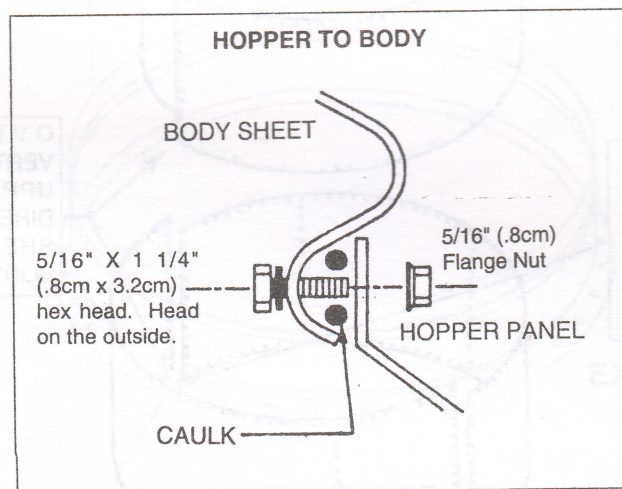

EXHIBIT J

Attach the first hopper panel, with the panels right edge seven (7) holes to the left of one of the bottom rings vertical leg holes.

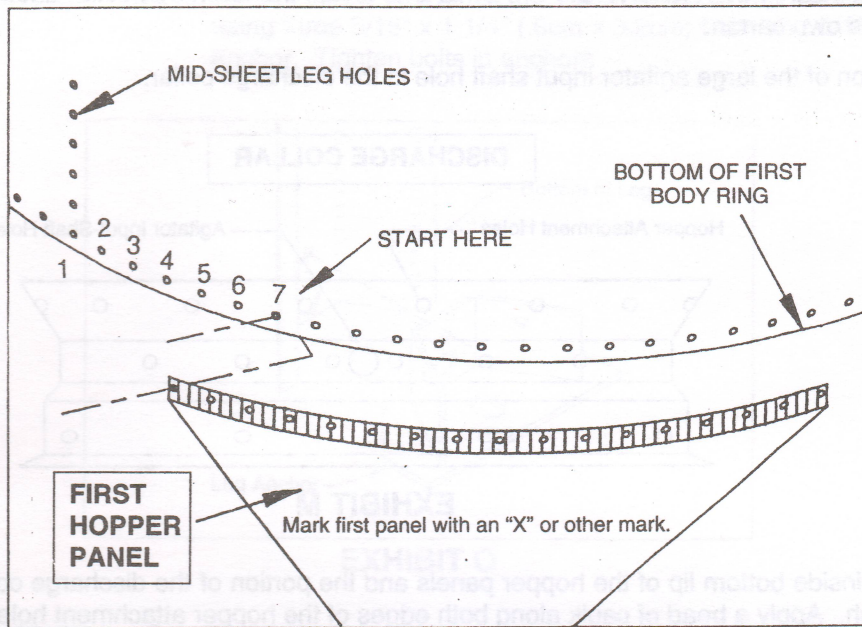

EXHIBIT K

The hopper panels will attach to the inside of the body with 5/16" x 1 1/4" (.8cm x 3.2cm) bolts and 5/16" flange nuts, bolt heads on the outside.

Apply a bead of caulk along both sides of the row of holes in the long edge of the hopper panel that has the bend towards the outside of the bin. Install the second hopper panel, overlapping the caulked edge of the first, and attach with 5/16" x 1 1/4" (.8cm x 3.2cm) bolts and 5/16" (.8cm) flange nuts at the hopper-to-body seam. Align the bolt holes in the hopper vertical seam with the reinforcement angle and install 5/16" x 3/4" (.8cm x 1.9cm) slotted truss head bolts and 5/16" (.8cm) flange nuts, bolt heads to the inside. See EXHIBIT L.

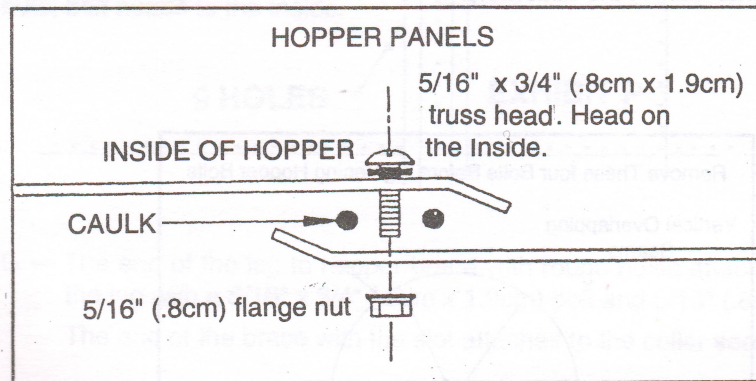

EXHIBIT L

Continue installing hopper panels, maintaining the same caulking and bolting pattern. However, DO NOT install the last hopper panel yet.

DISCHARGE COLLAR INSTALLATION – At this time locate the discharge collar and mounting hardware. This is supplied in its own carton.

Note the location of the large agitator input shaft hole in the discharge collar.

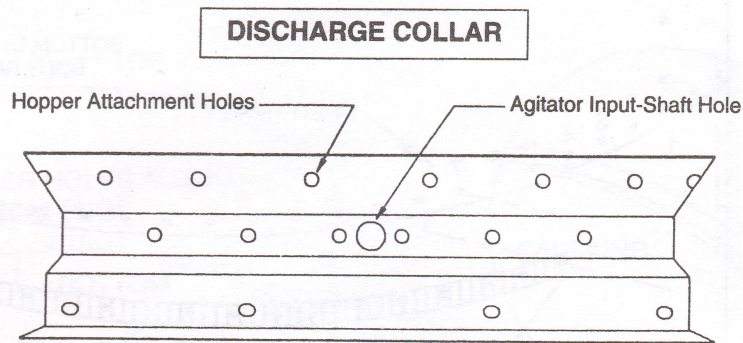

EXHIBIT M

Wipe down the inside bottom lip of the hopper panels and the portion of the discharge collar to which the hopper panels will attach. Apply a bead of caulk along both edges of the hopper attachment holes in the discharge collar (see EXHIBIT M). Insert the discharge collar into the bottom end of the hopper and align the agitator input shaft hole so that it will be centered directly between a pair of legs, away from the ladder and opener.

Situating the discharge collar in this manner will aid in the installation of an agitation device should you require one.

Use the agitator input shaft hole block-off plate, supplied with the discharge collar hardware, if you are not using an agitation device at this time.

Use the 5/16" x 3/4" (.8cm x 1.9cm) slotted truss head bolts and 5/16" (.8cm) flange nuts supplied with the discharge collar to attach the collar to the hopper, bolt heads to the inside.

Now install the last hopper section, caulking and bolting as before.

HOPPER TIGHTENING SEQUENCE – Before tightening any hopper connections, first locate the four bolts in the hopper-to-body seam which line up with the four sets of mid-sheet leg holes, and remove (see EXHIBIT N). Legs will attach at these points later in the assembly.

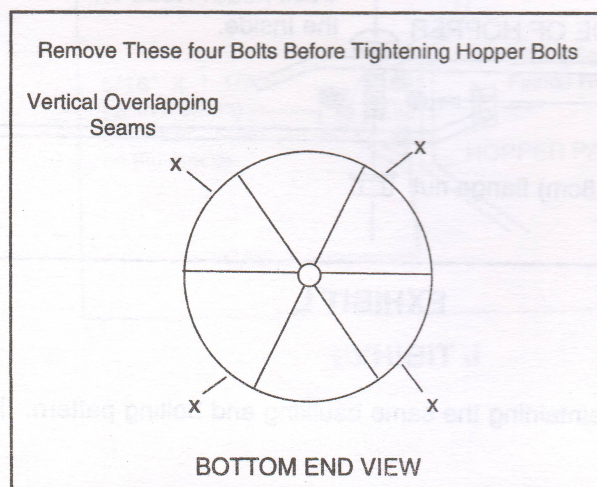

EXHIBIT N

STEP 6: LEG INSTALLATION – Attach one leg anchor to the bottom of each leg assembly (see Exhibit O) using three 5/16" x 1 1/4" (.8cm x 3.2cm) bolts and 5/16" hex nuts for each anchor. Tighten bolts in anchors.

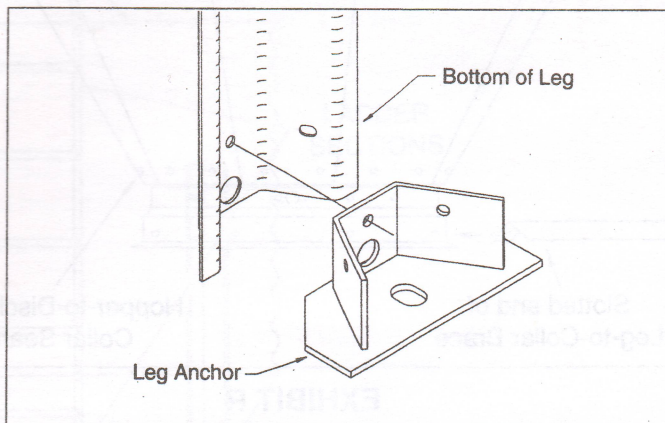
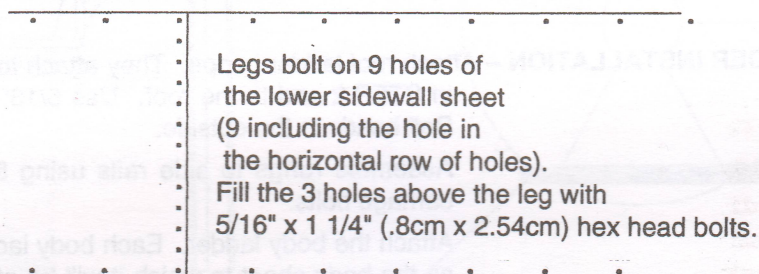
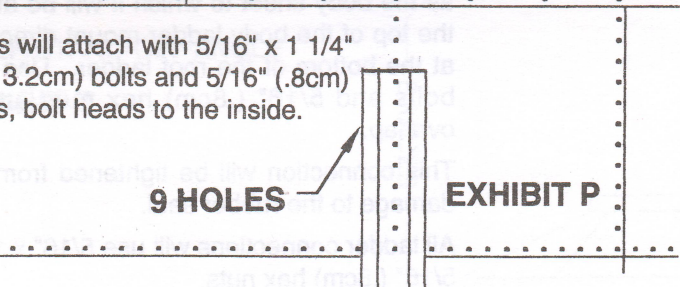

EXHIBIT O

Attach the legs to the bin body. See Exhibit P. A leg assembly will attach at each bottom sidewall sheet in the mid sheet set of vertical holes. The legs will bolt up as shown in Exhibit P.



The legs will attach with 5/16" x 1 1/4" (.8cm x 3.2cm) bolts and 5/16" (.8cm) hex nuts, bolt heads to the inside.



INSTALL LEG BRACING — The end of the leg to hopper brace with round holes attaches to the fifth hole up on the leg with a 5/16" x 3/4" (.8cm x 1.9cm) bolt and 5/16" (.8cm) hex nut. The end of the brace with the slot attaches to the collar seam. (see Exhibit Q).

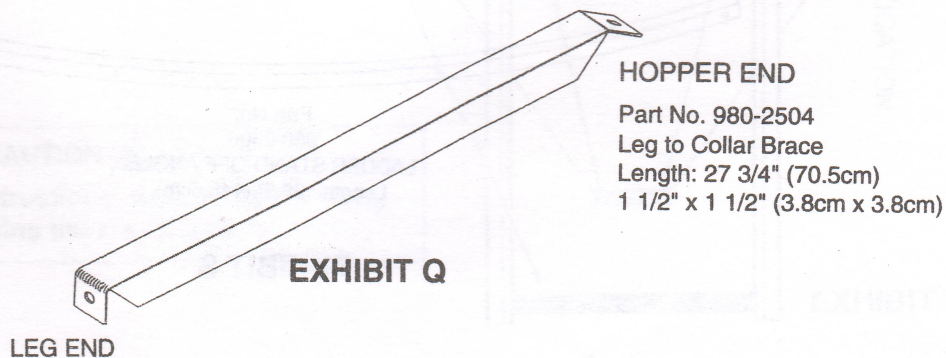

EXHIBIT Q

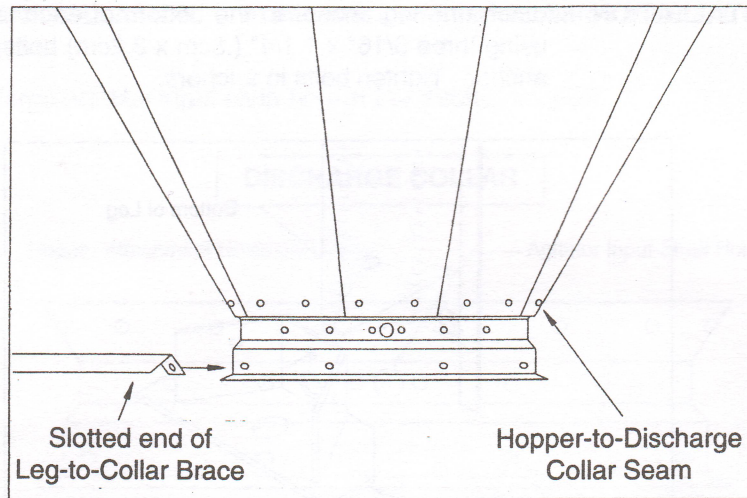

EXHIBIT R

Begin tightening all leg and bracing connections.

First tighten all bolts that attach the legs to the bin body, from the nut side ONLY.

Next tighten the hopper-to-discharge collar seam, from the nut side.

NOTE: DOUBLE CHECK ALL CONNECTIONS TO MAKE SURE ALL BOLTS HAVE BEEN TIGHTENED SECURELY.

If you are not using a ladder, please skip Step 7.

STEP 7: LADDER INSTALLATION – Attach roof ladder hoops. They attach to the holes you marked “ladder” in STEP 2 and to the roof. Use 5/16" x 1 1/4" (.8cm x 3.2cm) bolts. Bolt heads to the outside.

Assemble rungs to side rails using 5/16" x 1 1/2" (.8cm x 3.8cm) carriage bolts.

Attach the body ladder. Each body ladder section is the same height as the body sheet to which it will be attached. The mounting tabs at the top of the body ladder mount directly on top of the mounting tabs at the bottom of the roof ladder. Use 5/16" x 1 1/4" (.8cm x 3.2cm) bolts and 5/16" (.8cm) hex nuts at the roof ladder/body ladder overlap.

This connection will be tightened from the bolt-head end to prevent damage to the rubber seal.

All ladder connections will use 5/16" x 1 1/4" (.8cm x 3.2cm) bolts and 5/16" (.8cm) hex nuts.

The last body ladder attaches to one standoff angle. See Exhibit S and Exhibit T. The standoff attaches using 5/16" x 1 1/4" (.8cm x 3.2cm) bolts.

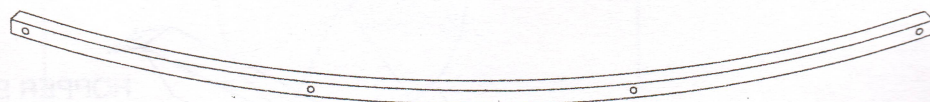

Part No.

980-2506

LADDER STAND-OFF ANGLE .

Length: 58.5" (148.6cm)

EXHIBIT S

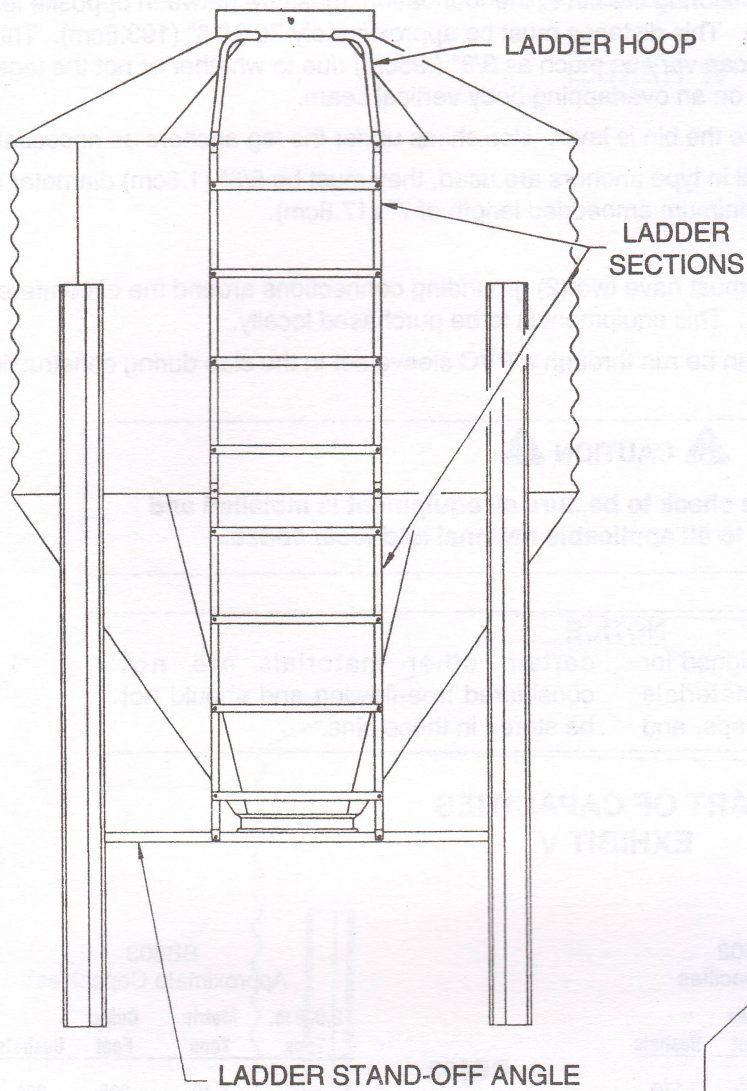

EXHIBIT T

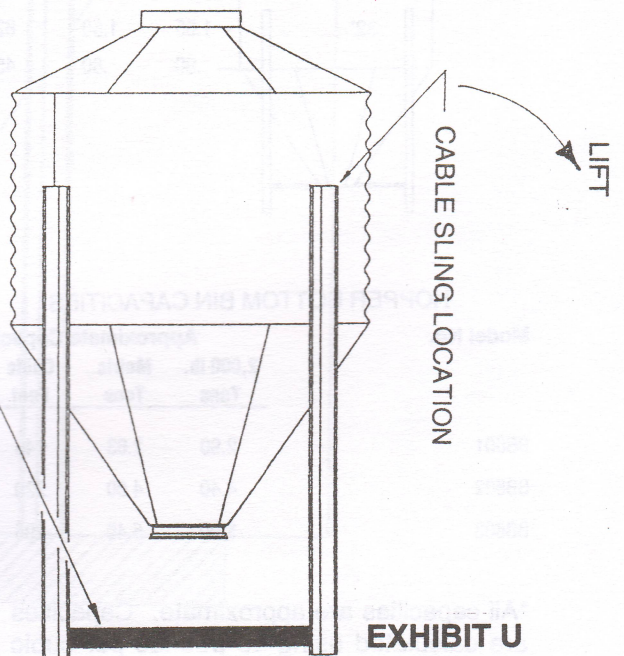
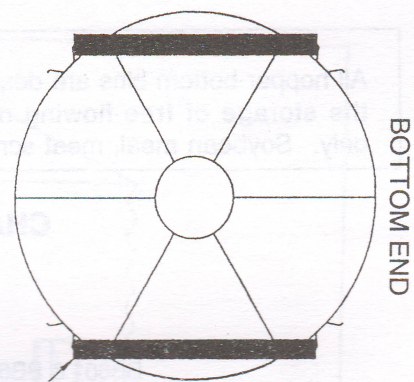

EXHIBIT U

STEP 8: Install the lid assembly following the instructions provided in its carton.

STEP 9: Raise the bin to vertical position.

⚠ CAUTION ⚠

Check for overhead obstructions, such as power lines, before standing the bin upright.

STEP 10: BIN ANCHORING – Before anchoring the bin to the foundation, measure between opposite legs of the bin. This distance must be approximately 76 3/16" (193.5cm). This distance can vary as much as 3/8" (.95cm) due to whether or not the legs are mounted on an overlapping body vertical seam.

Make sure the bin is level. Use shims under the leg anchors as necessary.

When drill in type anchors are used, they must be 5/8" (1.6cm) diameter and have a minimum embedded length of 7" (17.8cm).

STEP 11: BIN GROUNDING – Each bin must have two (2) grounding connections around the circumference of the bin. This equipment is to be purchased locally.

Cables can be run through a PVC sleeve set in the slab during construction.



Have a qualified electrician check to be sure all equipment is installed and grounded according to all applicable national and local codes.

NOTICE

All hopper-bottom bins are designed for the storage of free-flowing materials only. Soybean meal, meat scraps, and certain other materials are **not** considered free-flowing and should not be stored in these bins.

**CHART OF CAPACITIES
EXHIBIT V**

BB601 & BB602 Approximate Capacities					BB603 Approximate Capacities				
	2,000 lb. Tons	Metric Tons	Cubic Feet	Bushels		2,000 lb. Tons	Metric Tons	Cubic Feet	Bushels
	4.40	4.00	220	176		5.90	5.40	295	236
	3.90	3.60	196	157		5.40	5.00	272	217
	3.15	2.90	158	127		4.65	4.30	234	187
	2.40	2.20	120	96		3.90	3.60	196	157
	1.65	1.50	82	66		3.15	2.90	158	127
	.90	.80	45	36		2.40	2.20	120	96

HOPPER BOTTOM BIN CAPACITIES

Model No.	Approximate Capacities			
	2,000 lb. Tons	Metric Tons	Cubic Feet	Bushels
BB601	2.90	2.63	145	116
BB602	4.40	4.00	220	176
BB603	5.90	5.40	295	236

*All capacities are approximate. Capacities are calculated using 40 pounds per cubic foot; 50 pounds per bushel.

Height Specifications

EXHIBIT W

'A' = Discharge Collar Height - Inches (cm)
'B' = Overall Bin Height - Feet (Meters)

MODEL NUMBER	A	B
BB601	26 1/2" (67.3cm)	10' 2 1/4" (3.12m)
BB602	26 1/2" (67.3cm)	12' 10 3/4" (3.93m)
BB603	26 1/2" (67.3cm)	15' 6 1/4" (4.74m)

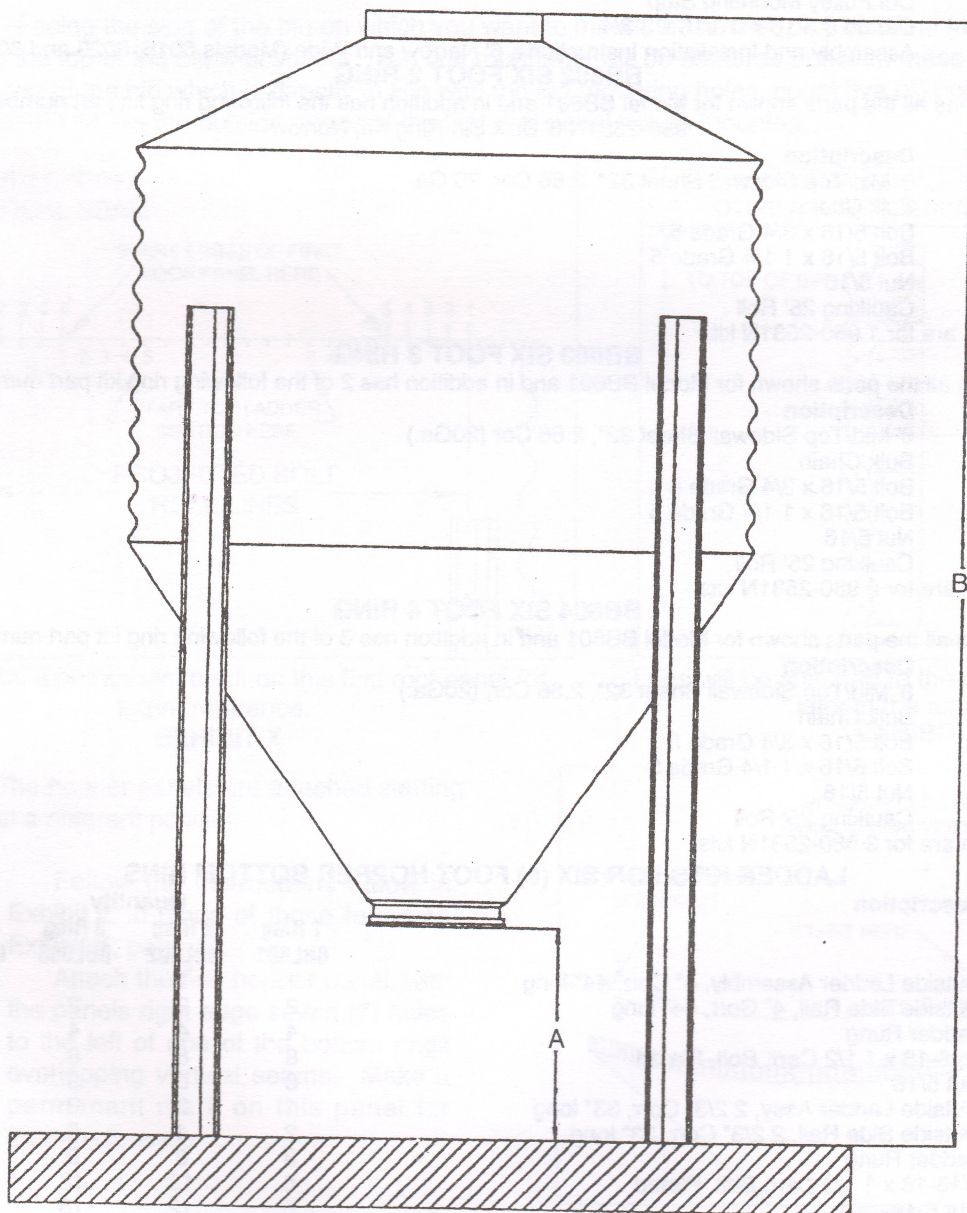

**BILLS OF MATERIAL/REPAIR PARTS LIST
SIX (6) FOOT DIAMETER HOPPER BOTTOM BIN
NARROW CORRUGATION (2.66" – 6.76CM)
BB601 SIX FOOT 1 RING**

Part No.	Description	Quantity
980-2501	6' Roof Section (22 ga)	6
980-2502	6' Hopper Section (20 ga)	6
980-2507N	6' Bottom Sidewall Sheet 32", 2.66 Cor, (20 Ga.)	2
950-1337G	Bin Leg, 92.75"	4
980-2504	Leg to Collar Brace (12 ga), 27.75"	4
319052	Collar Assembly w/Bolts	1
311209	Ftl. Lid Assy. w/Collar	1
312976	Ftl. Chain Kit	1
43814	S Hook	2
980-2510N	Hardware package for BB601	1
950-1197	4" Leg Anchor Bracket Assembly (foot at bottom of each leg)	4
907-0051	Caulking 25' Roll	8
907-0612	Bolt 5/16 x 3/4 Grade 5	90
907-0619	Bolt 5/16 x 1 1/4 Grade 5	270
907-0613	Nut 5/16	260
907-8001	5/16 x 3/4 Truss Hd. Grade 8 w/seal	80
907-8002	5/16 Flange Nut	180
OF121	5/16 Flat Washer	2
980-2625	Dbt Pulley Mounting Strip	2
UA1-C	Carton 9 3/16 x 9 3/16 x 3 3/4	1
ISHBB6	Assembly and Installation Instructions, 6' Narrow and Wide (Models 6015, 6025 and 6035)	1

BB602 SIX FOOT 2 RING

Model BB602 has all the parts shown for Model BB601 and in addition has the following ring kit part number 980-2531N.
980-2531N 6' Bulk Bin Ring Kit, Narrow

Part No.	Description	Quantity
980-2508N	6' Mid/Top Sidewall Sheet 32", 2.66 Cor, 20 Ga.	2
311214	Bulk Chain	64"
907-0612	Bolt 5/16 x 3/4 Grade 5	25
907-0619	Bolt 5/16 x 1 1/4 Grade 5	25
907-0613	Nut 5/16	50
907-0051	Caulking 25' Roll	2

Quantities shown are for 1 980-2531N kit.

BB603 SIX FOOT 3 RING

Model BB603 has all the parts shown for Model BB601 and in addition has 2 of the following ring kit part number 980-2531N.

Part No.	Description	Quantity
980-2508N	6' Mid/Top Sidewall Sheet 32", 2.66 Cor (20Ga.)	4
311214	Bulk Chain	128"
907-0612	Bolt 5/16 x 3/4 Grade 5	50
907-0619	Bolt 5/16 x 1 1/4 Grade 5	50
907-0613	Nut 5/16	100
907-0051	Caulking 25' Roll	4

Quantities shown are for 2 980-2531N kits.

BB604 SIX FOOT 4 RING

Model BB604 has all the parts shown for Model BB601 and in addition has 3 of the following ring kit part number 980-2531N.

Part No.	Description	Quantity
980-2508N	6' Mid/Top Sidewall Sheet 32", 2.66 Cor, (20Ga.)	6
311214	Bulk Chain	192"
907-0612	Bolt 5/16 x 3/4 Grade 5	75
907-0619	Bolt 5/16 x 1 1/4 Grade 5	75
907-0613	Nut 5/16	150
907-0051	Caulking 25' Roll	6

Quantities shown are for 3 980-2531N kits.

LADDER KITS FOR SIX (6) FOOT HOPPER BOTTOM BINS

Part No.	Description	Quantity			
		1 Ring BBL601	2 Ring BBL602	3 Ring BBL603	4 Ring BBL604
988-1000	Outside Ladder Assembly, 4" Corr. 44" long	1	1	1	1
988-1001	Outside Side Rail, 4" Corr, 44" long	2	2	2	2
988-1002	Ladder Rung	4	4	4	4
907-9050	5/16-18 x 1 1/2 Carr. Bolt, Plated	8	8	8	8
907-0613	Nut 5/16	8	8	8	8
988-1010	Outside Ladder Assy, 2 2/3" Corr, 33" long	1	2	3	4
988-1011	Outside Side Rail, 2 2/3" Corr, 33" long	2	4	6	8
988-1002	Ladder Rung	3	6	9	12
907-9050	5/16-18 x 1 1/2 Carr. Bolt, Plated	6	12	18	24
907-0613	Nut 5/16	6	12	18	24
980-2506	Ladder Stand-Off Angle, 58"	1	1	1	1
988-1020	Ladder Hoop, 6' Bin	2	2	2	2

WIDE CORRUGATION (4.00" – 10.16CM)

SIX (6) FOOT DIA. HOPPER BOTTOM BIN ASSEMBLY AND INSTALLATION INSTRUCTIONS AND REPAIR PARTS LIST

INSTRUCTIONS

MODEL NO.	DESCRIPTION	CAPACITY *
BB6015	6 Ft. (1.83 Meters) Dia. / One 44" (111.8 cm) Ring	3.45 tons
BB6025	6 Ft. (1.83 Meters) Dia. / Two 44" (111.8 cm) Rings	5.50 tons
BB6035	6 Ft. (1.83 Meters) Dia. / Three 44" (111.8 cm) Rings	7.55 tons

* Capacity is in 2000 pound tons. For metric tons, cubic feet and bushels see page 22.

With wide corrugation models, follow the general sequence as shown in the previous pages. However, please note these exceptions:

STEP 2: The legs mount on the vertical seams and on the mid sheet set of vertical holes. Follow the hole positioning as shown below in Exhibit X in place of Exhibit D, on page 9.

—Facing the side of the bin on which you want to mount the ladder, project a line from the leg mounting holes up to the top of the bin wall sheets. The first roof panel will be centered between these legs. From the hole at the top of the bin which is directly in line with the leg mounting holes, count five (5) holes in from each leg. These holes are where the outside edges of the first roof panel will be mounted.

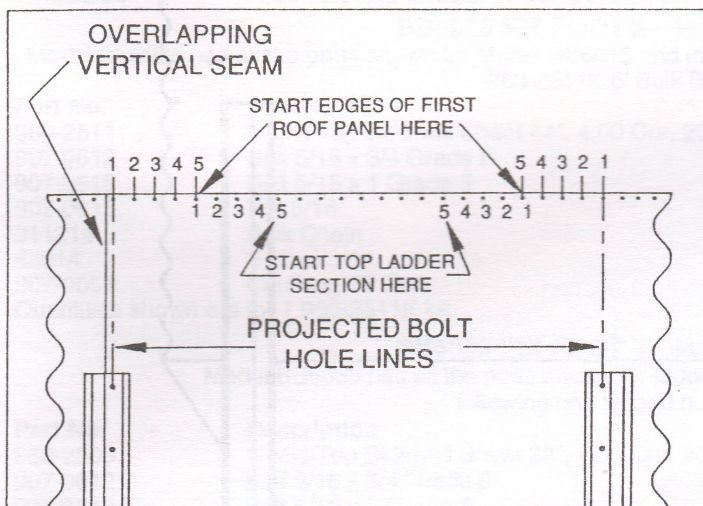

NOTE: Make a permanent mark on this first roof panel for future reference.

EXHIBIT X

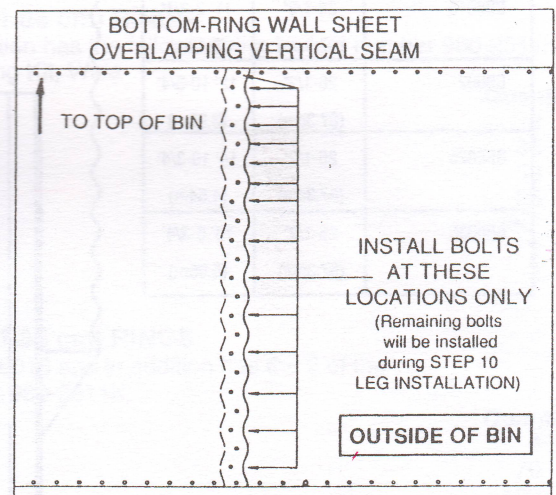

Legs will be attached to the outward corrugations later in the assembly.

EXHIBIT Y

STEP 5: The hopper panels are attached starting at a different position.

Follow the instructions below in Exhibit Z in place of those found on Exhibit K, page 13.

Attach the first hopper panel, with the panels right edge seven (7) holes to the left of one of the bottom rings overlapping vertical seams. Make a permanent mark on this panel for future reference.

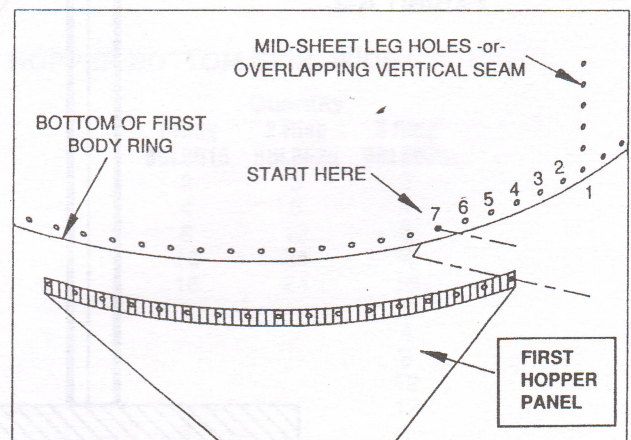

EXHIBIT Z

Before tightening any hopper connections, first locate the bolts in the hopper to body seam which line up with the three body ring overlapping seams. Legs will attach at these points so the fasteners do not need to be tightened.

Chart of Capacities EXHIBIT A-1

BB6015 & BB6025 Approximate Capacities

	2,000 lb. Tons	Metric Tons	Cubic Feet	Bushels
5.50	5.00	275	220	
5.00	4.55	250	200	
44"	3.97	3.60	199	159
2.95	2.70	148	119	
44"	1.93	1.75	97	78
.90	.80	45	36	

HOPPER BOTTOM BIN CAPACITIES

Model No.	APPROXIMATE CAPACITIES			
	2000 lb. Tons	Metric Tons	Cubic Fl. (Meters)	Bushels
BB6015	3.45	3.13	173	140
BB6025	5.50	5.00	275	223
BB6035	7.55	6.86	377	306

*40 pounds per cubic foot

'A' = Discharge Collar Height - Inches (cm)
'B' = Overall Bin Height - Feet (Meters)

MODEL NUMBER	A	B
BB601	26-1/2" (67.3cm)	10' 2-3/4" (3.12m)
BB6015	26-1/2" (67.3cm)	11' 2-3/4" (3.42m)
BB602	26-1/2" (67.3cm)	12' 10-3/4" (3.93m)
BB6025	26-1/2" (67.3cm)	14' 10-3/4" (4.54m)
BB6035	26-1/2" (67.3cm)	16' 6-3/4" (5.05m)

Height Specifications EXHIBIT A-2

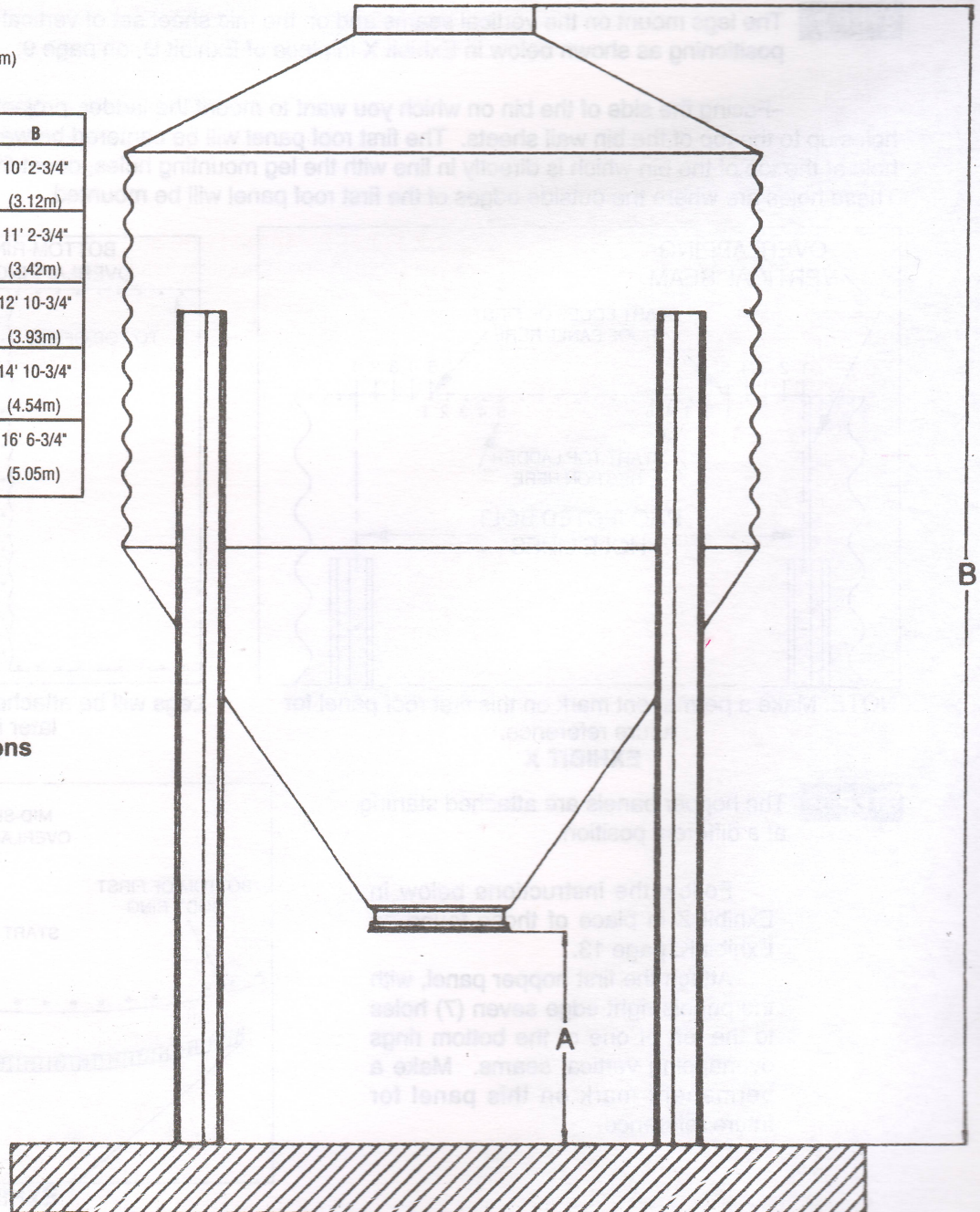

EXHIBIT A-1

**BILLS OF MATERIAL/REPAIR PARTS LIST
SIX (6) FOOT DIAMETER HOPPER BOTTOM BIN
WIDE CORRUGATION (4.00" - 10.16 CM)**

BB6015 SIX FOOT 1 - 44" (111.8 CM) RING

Part No.	Description	Quantity
980-2501	6' Roof Section (22 ga)	6
980-2502	6' Hopper Section (20 ga)	6
980-2503	6' Bottom Sidewall Sheet 44", 4.00 Cor, (20 Ga.)	2
950-1337G	Bin Leg, 92.75"	4
980-2504	Leg to Collar Brace (12 ga), 27.75"	4
319052	Collar Assembly w/Bolts	1
311209	Ftl. Lid Assy. w/Collar	1
312976	Ftl. Chain Kit	1
980-2510	Hardware package for BB601	1
950-1197	4" Leg Anchor Bracket Assembly (foot at bottom of each leg)	4
907-0051	Caulking 25' Roll	8
907-0612	Bolt 5/16 x 3/4 Grade 5	85
907-0618	Bolt 5/16 x 1 Grade 5	205
907-0613	Nut 5/16	195
907-8001	5/16 x 3/4 Truss Hd. Grade 8 w/seal	80
907-8002	5/16 Flange Nut	180
907-0620	3/8 x 1 Bin Bolt	75
907-0622	3/8 - 16 Hex Nut	75
OF121	5/16 Flat Washer	2
980-2625	Dbl Pulley Mounting Strip	2
UA1-C	Carton 9 3/16 x 9 3/16 x 3 3/4	1
ISHBB6	Assembly and Installation Instructions, 6' Narrow and Wide	1

BB6025 SIX FOOT 2- 44" (111.86 cm) RINGS

Model BB6025 has all the parts shown for Model BB6015 and in addition has the following ring kit part number 980-2511K.
980-2511K 6' Bulk Bin Ring Kit, Wide

Part No.	Description	Quantity
980-2511	6' Mid/Top Sidewall Sheet 44", 4.00 Cor, 20 Ga.	2
907-0612	Bolt 5/16 x 3/4 Grade 5	35
907-0618	Bolt 5/16 x 1 Grade 5	50
907-0613	Nut 5/16	85
311214	Bulk Chain	88"
43814	S Hook	2
907-0051	Caulking 25' Roll	3

Quantities shown are for 1 980-2511K kit.

BB6035 SIX FOOT 3- 44" (111.86 cm) RINGS

Model BB6035 has all the parts shown for Model BB6015 and in addition has the 2 of the following ring kit part number 980-2511K.

Part No.	Description	Quantity
980-2508	6' Mid/Top Sidewall Sheet 32", 4.00 Cor, 20 Ga.	4
907-0612	Bolt 5/16 x 3/4 Grade 5	70
907-0618	Bolt 5/16 x 1 Grade 5	100
907-0613	Nut 5/16	170
311214	Bulk Chain	176"
43814	S Hook	2
907-0051	Caulking 25' Roll	4

Quantities shown are for 2 980-2511K kits.

LADDER KITS FOR SIX (6) FOOT HOPPER BOTTOM BINS, WIDE

Part No.	Description	Quantity		
		1 Ring BBL6015	2 Ring BBL6025	3 Ring BBL6035
980-1000	Outside Ladder Assembly, 4" Corr. 44" long	2	3	2
988-1001	Outside Side Rail, 4" Corr, 44" long	4	6	4
988-1002	Ladder Rung	8	12	8
907-9050	5/16-18 x 1 1/2 Carr. Bolt, Plated	16	24	16
907-0613	Nut 5/16	16	24	16
988-1010	Outside Ladder Assembly, 33" Long			2
988-1011	Outside Side Rail, 33" Long			4
988-1002	Ladder Rung			6
907-9050	5/16-18 x 1 1/2 Carr. Bolt, Plated			12
907-1613	Nut 5/16			12
980-2506	Ladder Stand-Off Angle, 58"	1	1	1
988-1020	Ladder Hoop, 6' Bin	2	2	2

FIELD MODIFICATIONS AND MAINTENANCE

Our HSPI bin is a low maintenance product when used as described. In all cases there is maintenance or modification required as the bin ages. We recommend these be done as soon as the need arises. A scheduled maintenance program on all your equipment is recommended to maintain a quality facility.

1. The anchor bolts are an important structural component. Make sure they stay clean of debris and moisture to reduce corrosion.
2. Tighten the anchor bolts anytime they show signs of being loose.
3. Any caked material in the hopper should be cleaned by mechanical brushing either dry or high pressure wet system. This should be done by access through the discharge collar.
4. Reseal any area where there is a sign of leaking or moisture.
5. Galvanize will age and turn dark which is normal but any white or red rust needs to be cleaned and treated to prevent major damage.

Red rust should be treated by wire brushing, cleaning, and painting with a good rust inhibitor, then paint with a galvanize paint.

White rust should be rubbed down with cleaner (diesel fuel, white vinegar). Then washed off with water.

At the first sign of deterioration (rust, cracks, etc.) replace ladders, or any other weight bearing parts. DO NOT PAINT OVER THESE.

6. Any field modifications that affect the structural stability of the bin or create a possible hazard must be approved in writing by an authorized representative from the manufacturer.
7. Be absolutely sure all shields and guards are replaced after doing maintenance to belts, chains, or any other moving parts.
8. At any time large cracks appear or any type of chipping or flaking of the concrete occur, contact your dealer for ways to repair these areas before they become a serious threat to the stability of your bin.

WARRANTY

Hawkeye Steel Products, Inc. (HSPI) warrants its hopper bottom bins to be free from defects in material or workmanship for one year from the date of initial installation by the original purchaser. If such a defect is found by HSPI to exist within the one year period, HSPI will, at its option, (a) repair or replace such product free of charge, F.O.B. the factory of manufacture, or (b) refund to the original purchaser the original purchase price, in lieu of such repair or replacement.

CONDITIONS AND LIMITATIONS

1. This product must be purchased from and installed by an authorized HSPI dealer or one of its certified representatives or the warranty will be void.
2. The product must be installed and operated in accordance with instructions published by HSPI or warranty will be void.
3. Malfunctions or failure resulting from misuse, abuse, negligence, alteration, accident, or lack of proper maintenance shall not be considered defects under this warranty.
4. HSPI bins are designed for grains and/or free flowing materials and are not warranted for other distribution or substances. Other use will void warranty.

HSPI shall not be liable for any consequential or special damage which any purchaser may suffer or claim to suffer as a result of any defect in the product. "Consequential" or "special damages" as used herein include but are not limited to lost or damaged products or goods, costs of transportation, lost sales, lost orders, lost income, increased overhead, labor and incidental costs and operational inefficiencies.

THIS WARRANTY CONSTITUTES HSPI'S ENTIRE AND SOLE WARRANTY AND HSPI EXPRESSLY DISCLAIMS ANY AND ALL OTHER WARRANTIES, INCLUDING BUT NOT LIMITED TO EXPRESS AND IMPLIED WARRANTIES AS TO MERCHANTABILITY, FITNESS FOR PARTICULAR PURPOSE SOLD AND DESCRIPTION OR QUALITY OF THE PRODUCT FURNISHED HEREUNDER.

Any exceptions to this warranty must be authorized in writing by an officer of the company. HSPI reserves the right to change models and specifications at any time, without notice or obligation.